

# Operation, assembly and maintenance instructions for discontinuous sampling Series 27h



Fig. 1 - Drainage - Sampling valve Series 27h



The equipment may only be dismantled and disassembled by skilled staff who are familiar with the assembly, start-up and the operation of this product.

Skilled staff in the sense of these repair and assembly instructions are persons who, as a result of their training, knowledge and their experience, also their knowledge of the relevant standards, are able to judge the tasks assigned to them and are able to recognise possible dangers.

## 1. Design, operation and dimensions

Design, operation and dimensions as well as all further details and technical data may be found in the **Data sheet < TB 27h\_EN >**.

## 2. Installation, start-up and maintenance

Guidelines for the installation, start-up and maintenance can be found in the respective operating instructions for sampling valves.

## 0. Introduction

These instructions are intended to support the user in the assembly and repair of sampling valves of the Series 27h.

Technical details, as a result of the further development of the valves mentioned in these instructions, are subject to modification. The text and illustrations do not necessarily display the scope of supply or an eventual order of spare parts. Drawings and graphics are not to scale. Customer related special designs, which are not in accordance with our standard offer, are not shown.

The transfer of these instructions to third parties is only allowed with the written approval of Pfeiffer Chemie-Armaturenbau GmbH. All documents are protected according to the laws of the German Copyright Act.

The transmission and/or duplication of documents, even in abstracts, as well as the exploitation and communication of their content is not permitted, unless expressly granted. Violations are an offence and liable to claims for damages. We reserve all rights for the exercise of industrial property rights.

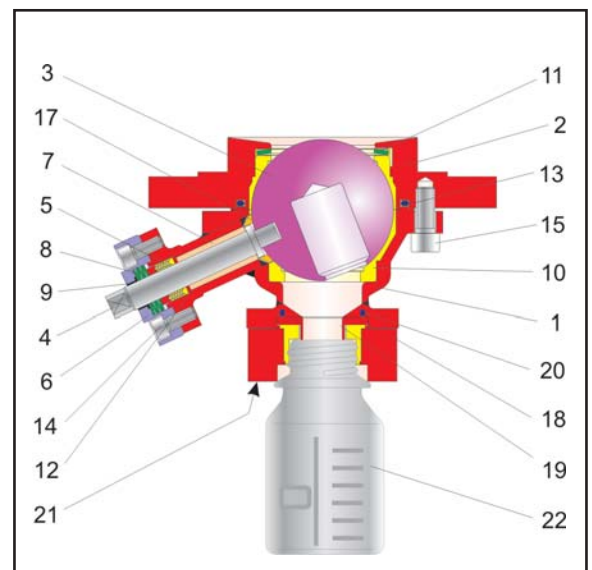

Fig. 2 - Sectional view of sampling valve Series 27h => Parts list see table 1

# Sampling valve Series 27h

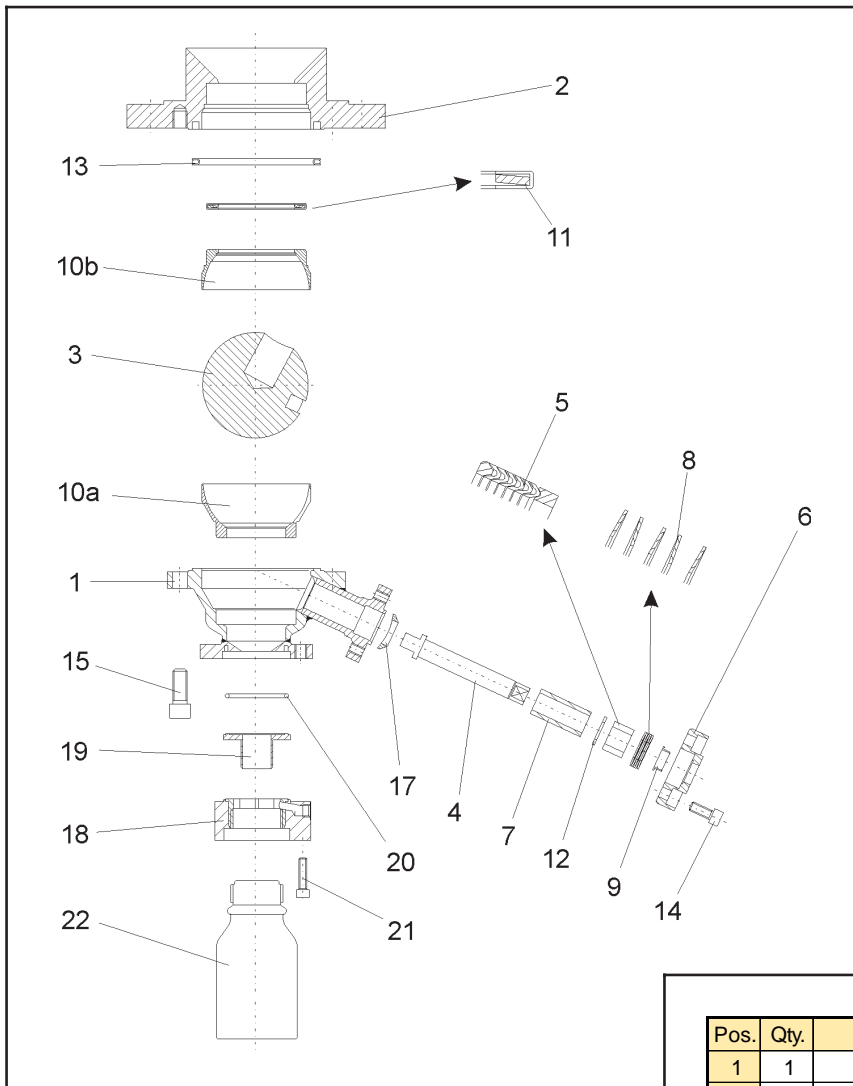

Fig. 3 - Explosion drawing of the sampling valve Series 27h

## 3. Assembling the sampling valve

### 3.1 Preparation for assembly

To assemble the sampling valve, thoroughly clean all parts and lay them on soft padding ( Gummimatte ect.) Take into account that parts made of plastic are nearly always soft and very sensitive and especially the sealing surfaces must not be damaged.



**Note:** The position and arrangement of the individual parts shown in the exploded drawing must be complied to when assembling the valve.

### 3.2 Assembly of the sampling valve

#### • Initial assembly of the drain valve body

Place the draining valve body ( 1 ) with the outlet flange facing downwards on a clean surface, and with the stuffing box flange side accessible for all assembly work for the fitter. Place the seat ring ( 10a ) in the body. The ball ( 3 ) is inserted.

Position the ball, so the recess in the ball is aligned for the control shaft ( 4 ) to be inserted. Now insert the control shaft ( 4 ). With the appropriate tool, press the lower bearing bushing ( 7 ) in the intended position. Place the body sealing ( 13 ) in the drain valve body.

#### • Initial assembly of the body inlet

Place the lined spring washer ( 11 ) in the body inlet ( 2 ). The positioning of the spring washer is shown in the explosion drawing ( Bild 3 ).

The seat ring ( 10b ) ( sharp edged steel rim housing ) is positioned on the spring washer.

| Pos. | Qty. | Description         | Material             |
|------|------|---------------------|----------------------|
| 1    | 1    | Body outlet         | 1.4571               |
| 2    | 1    | Body inlet          | 1.4408               |
| 3    | 1    | Ball                | 1.4571               |
| 4    | 1    | Control shaft       | 1.4571               |
| 5    | 1    | V-ring packing      | 1.4305 / PTFE        |
| 6    | 1    | Stuffing box flange | 1.4571               |
| 7    | 1    | Bearing bushing     | PTFE with glass      |
| 8    | 1    | Spring washer set   | 1.8159 - Delta Tone  |
| 9    | 1    | Bearing bushing     | PTFE with carbon     |
| 10   | 1    | Seat ring           | TFM                  |
| 11   | 1    | Spring washer       | 1.4310               |
| 12   | 1    | Thrust washer       | 1.4305               |
| 13   | 1    | Body sealing        | PTFE                 |
| 14   | 4    | Schraube            | A2-70                |
| 15   | 4    | Screw               | A2-70                |
| 16   | 1    | Nut                 | A2-70                |
| 17   | 1    | Ring                | TFM                  |
| 18   | 1    | Bonnet              | 1.4571/PTFE-40%glass |
| 19   | 1    | Funnel              | 1.4571               |
| 20   | 1    | O-ring              | Viton                |
| 21   | 4    | Screw               | A2-70                |
| 22   | 1    | Sample bottle       | Glass                |

Table 1 - List of parts

• **Assembly of the body parts**

Carefully mount the body inlet ( 2 ) together with the pre-assembled seat ring ( 10b ) on the body outlet ( 1 ) and press both together.

Turn the body inlet ( 2 ) so that the bores of both body parts ( 1 und 2 ) are aligned.

After lightly apply grease to the screws ( 15 ) e.g. stud bolts and nuts ( 16 ), tighten the screws evenly and in alternating pattern. With the appropriate tool, the V-ring packing ( 5 ) is inserted in the bore of the body, in the following order; Steel ring, PTFE- ground ring, PTFE-V-rings and steel-V-ring. For exact positioning and location of the V-rings, refer to the explosion drawing ( Fig. 3 ) Now place the spring washer set ( 8 ) on the packing. Refer to the explosion drawing for exact positioning of the springs. ( Fig. 3 ).

Press the bearing bushing ( 9 ) into the stuffing box flange ( 6 ). Following this, mount the stuffing box flange over the control shaft and onto the body. Align, and tighten the screws (14) with approx. 50 Nm evenly and in alternating pattern. To complete the assembly, tighten the screws ( 15 ) and the hexagon nuts ( 16 ) connecting the body parts to 65 Nm.



**Note:** Before testing for leak tightness, the valve should be operated once or twice, to enable the ball to sit correctly in the sealing rings, therefore ensuring a good sealing function.

• **Checking the torque- and breakaway torques**

With the use of a torque wrench, the torque, and breakaway torques can be checked.

| Nominal diameter<br>DN | erf. Torque<br>Md | Breakaway torque<br>Mdl |
|------------------------|-------------------|-------------------------|
| 40                     | 20 Nm             | 39 Nm                   |
| 50                     | 20 Nm             | 39 Nm                   |
| 80                     | 60 Nm             | 110 Nm                  |
| 100                    | 95 Nm             | 176 Nm                  |
| 150                    | 190 Nm            | 349 Nm                  |

Table 2 - Torque

• **Final assembly of the sampling valve**

Place the O-ring ( 20 ) and the funnel ( 19 ) in the intended insert of the drain valve body ( 1 ).

Apply grease to the screws ( 21 ) ( e.g. Gleitmo grease 805, from Fuchs or similar ).

The bonnet is mounted ( 18 ) and aligned with the screws. Tighten the screws evenly, and in alternating pattern.

**The assembly of the sampling valve is finished**

**4. Trouble shooting**

Action to be taken in the event of a malfunction is described in the operating instructions for the sampling valve. You can also contact Pfeiffer Chemie-Armaturenbau GmbH directly if you require help.

**5. Repairing the drainage plug valve**

**5.1 Replacing the V-ring packing**

If leakage is located at the stuffing box, the PTFE-rings of the V-ring packing ( 5 ) may be defect. It is therefore recommended to check the packing.

To dismantle the V-ring packing, proceed in reverse order to the assembly as described in Section 3

Proceed to check the PTFE-rings of the V-ring packing as with all other plastic parts for damage, and if necessary replace all defect parts.

**5.2 Replacing the sealing seat and the ball**

If the ball valve does not shut-off tightly and leaks, the sealing rings ( 10a and 10b ) and ball ( 3 ) must be checked for damage.

To dismantle the sealing rings and the ball, proceed in reverse order to the assembly instructions described in Section 3.

Check the sealing rings and ball as with all other plastic parts for damage, and if necessary replace these parts.

**5.3 Other repairs**

We recommend large repairs being carried out in our factory by our skilled staff at Pfeiffer.

**6. Operating the sampling valve**

**6.1 Important general instructions**



According to the medium, it may be necessary to clean the sampling chamber, and blind hole after a sample has been taken. The operator must decide when this is necessary.

- It is absolutely important, that when taking a sample, the sampling container (glass bottle etc.) is adapted to the temperature of the media being taken!
- Safety precautions must be taken when the medium temperature exceeds 60°C as a risk of scalding is possible.
- When taking samples, the general accident prevention regulations must be complied with, at all times!

# Sampling valve Series 27h

## 6.2 Sampling valve with lever

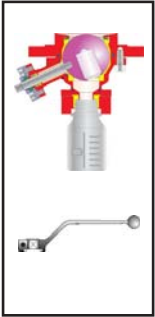

- Screw on the sample bottle by hand as tightly as possible.
- Turn handlever 180° until the bore is in the medium flow.
- Turn back the lever to allow the sample to flow into the bottle.
- Repeat this procedure until the required amount of media has been collected in the bottle.
- Unscrew the sample bottle, and if necessary seal bottle with a lid.

## 6.3 Sampling valve with lever and protective case



- Open protective case.
- Screw on the sample bottle by hand as tightly as possible.
- Close protective case.
- Turn the handlever 180° until the bore is in the media flow.
- Turn back the lever to allow the sample to flow into the bottle.
- Repeat this procedure until the required amount of media has been collected in the bottle.
- Open protective case, and remove sample bottle, and if necessary seal bottle with a lid.
- Close protective case.

## 6.4 Sampling valve with handlever, and protective case with support



- Open protective case.
- Pull down the support on the handlever.
- Place the sample bottle into the PTFE seat of the support.
- Guide the support upwards.
- Close protective case.
- Turn lever 180° until the bore is in the medium flow.
- Turn back the lever to allow the media to flow into the bottle
- Repeat this procedure until the required amount has been collected in the bottle.
- Open protective case, guide the support downwards, remove sample bottle, and if necessary seal bottle with a lid.
- Close protective case.

## 6.5 Sampling valve with automated 180° rotary actuator and protective case

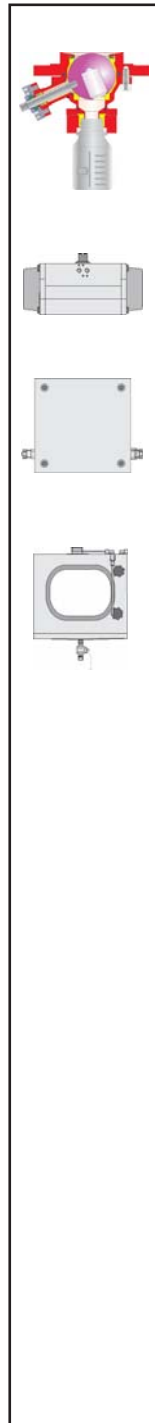

### 6.5.1 general automated sampling

- Open protective case.
- Screw on sample bottle by hand as tightly as possible.
- Close protective case.
- Open the air supply valve at the automation unit.
- **Attention:** Before operating, refer to the respective operating instructions for automation units, which can be found in **Section 7** ( Operating the automation unit )
- Close the air supply valve at the automation unit
- Open the protective case, remove the sample bottle, and if necessary seal bottle with a lid.
- Close protective case.

### 6.5.2 automated sampling with back pressure indication

- Operating this type of sampling is identical to the operating instructions in **Section 6.5.1**
- In addition to the above mentioned version, the following function is included:

- The automation switches off automatically, and no further sample can be taken when the sample level in the glass bottle reaches the back pressure tube!



### 6.5.3 automated sampling with pneumatic barrier

- Operating this type of sampling is identical to the operating instructions in **Section 6.5.1**
- In addition to the above mentioned version, the following function is included:
- The automation switches off automatically and no further sample can be taken when the protective case is opened.

## 6.6 Sampling valve with automated 180° rotary actuator and protective case with support

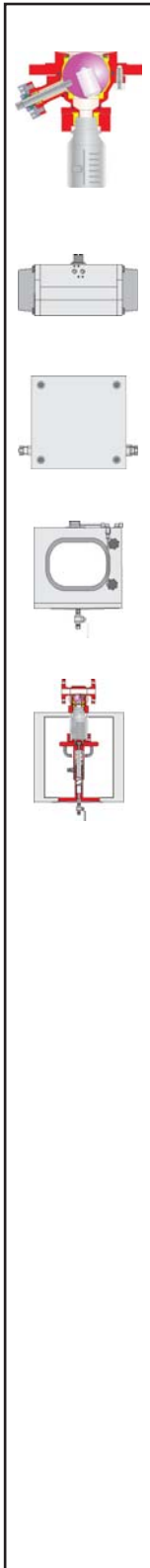

### 6.6.1 general automated sampling

- Open protective case.
- Pull down the support on the handlever.
- Place the sample bottle into the PTFE seat of the support.
- Guide the support upwards.
- Close protective case.
- Open the air supply valve at the automation unit.
- **Attention:** Before operating, refer to the respective operating instructions for the automated unit, which can be found in **Section 7** ( Operating the automation unit )
- Close the air supply valve at the automation unit.
- Open protective case, guide the support downwards, remove sample bottle and if necessary seal bottle with a lid.
- Close protective case.

### 6.6.2 automated sampling with back pressure indication

- Operating this type of sampling is identical to the operating instructions in **Section 6.6.1**
  - In addition to the above mentioned version, the following function is included:
    - The automation switches off automatically and no further sample can be taken when the sample level in the glass bottle reaches the back pressure tube!
-  When attaching the bottle, avoid at all times bending the tube!

### 6.6.3 automated sampling with pneumatic barrier

- Operation fo this type of sampling is identical to the operating instructions described in **Section 6.6.1**
- In addition to the above mentioned version, the following function is included:
  - The automation switches off automatically and no further sample can be taken when the protective case is opened during the sampling procedure.

## 7. Operation of automation units

### 7.1 Automation with „ON/OFF“ - Switch



**Note:** The pulse timing of actuation as well as the timing for filling the actuator with air or venting it are pre-set timings, which were set before leaving our works. Any alterations to these settings may only be made after first consulting Pfeiffer Chemie-Armaturenbau GmbH!

- Press the start button. A complete actuating cycle taking a sample is performed.
- Repeat this procedure until the required amount of medium has been collected in the bottle.

### 7.2 Automation with counter

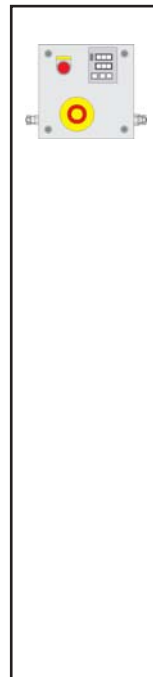

**Note:** The pulse timing and intervals between actuation cycles and the timing for filling the actuator with air or venting it, are pre-set timings, which were set before leaving our works. Any alteration to these settings may only be made after first consulting Pfeiffer Chemie-Armaturenbau GmbH!

- Set the number of actuating cycles at the counter.
- **Attention:** The selected number of actuating cycles must correspond to the volume of the sampling bottle.
- Press the start button. The pre-selected number of actuating cycles to take samples are performed.
- The sampling finishes automatically after the selected number of actuating cycles have been completed.



**Attention!** In the event of a operation malfunction, press the emergency button immediately.

# Sampling valve Series 27h

## 7.3 Automation with counter and timer switch



**Note:** The pulse timing of actuation and for filling the actuator with air or venting it, are pre-set timings, which are set before leaving our factory. Any alterations to these settings may only be made after first consulting Pfeiffer Chemie-Armaturenbau GmbH!

- The required interval between each actuation cycle can be set at the timer switch.

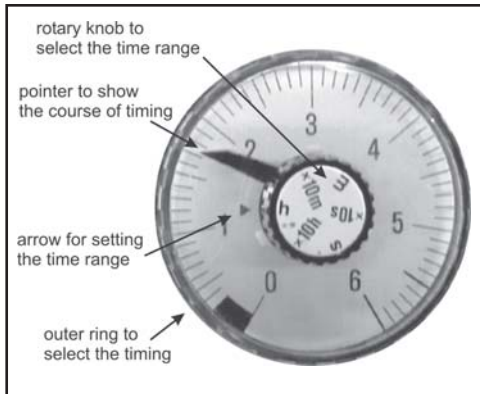

Fig. 4 - Samsomatic - Time switch 3970

- Select time range  
The switch-over range is selected with the rotary knob located in the middle of the timer, by setting the dial arrow to the required range.

| Selection | Time range       |
|-----------|------------------|
| s         | 0,3 to 6 seconds |
| x10s      | 3 to 60 seconds  |
| m         | 0,3 to 6 minutes |
| x10m      | 3 to 60 minutes  |
| h         | 0,3 to 6 hours   |
| x10h      | 3 to 60 hours    |

Table 3 - Time ranges

- Determine the required timing.  
The required cycle time can be set by turning the outer ring. A pointer indicates the cycle time.
- Set the number of actuation cycles at the counter.



**Attention:** The selected number of actuating cycles must correspond to the volume of the sample bottle.

- Press the start button.  
The pre-selected number of actuating cycles to take samples, together with the pre-selected intervals are performed.

- The sampling finishes automatically after the selected number of actuating cycles have been completed.



**Attention!** In the event of a malfunction, press the emergency button immediately.

## 8. Circuit diagram

Circuit diagram for the automation unit.

Should you have any questions, please contact Pfeiffer Chemie-Armaturenbau GmbH

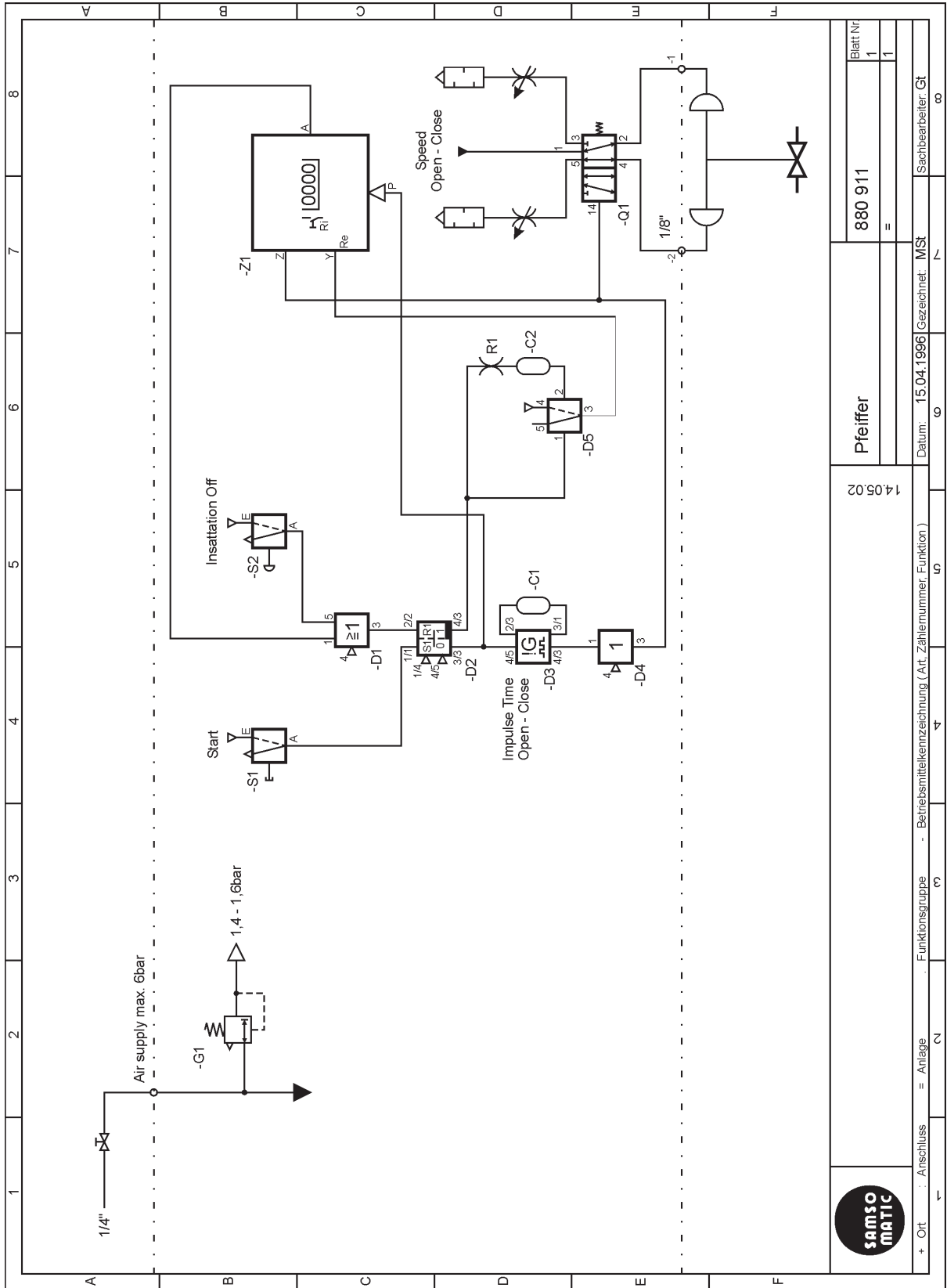

Fig. 5 - Circuit diagram

## 9. Customer inquiries

Details as per the check list for repairs and inquiries.

| <b>Check list for repairs and inquiries for the Sampling valve Series 27h</b> |   |
|---|---|
| <b>General</b>  | Commission number: ( embossed on the type plate) _____<br>Customer: _____<br>Telephone: _____ Fax: _____  |
| <b>Medium</b>   | Medium: _____<br>Temperature: _____ °C      op. pressure: _____ bar<br>Viscosity: <input type="checkbox"/> like water <input type="checkbox"/> like honey <input type="checkbox"/> like oil<br><input type="checkbox"/> others: _____<br>Characteristic: <input type="checkbox"/> toxic <input type="checkbox"/> caustic <input type="checkbox"/> corrosiveness<br><input type="checkbox"/> abrasiv <input type="checkbox"/> foaming <input type="checkbox"/> others: _____   |
| <b>Valve</b>  | Nominal size: <input type="checkbox"/> DN 25 <input type="checkbox"/> DN 50<br><input type="checkbox"/> DN 80 <input type="checkbox"/> DN 100<br><input type="checkbox"/> sampling volume 1 to 25ml _____   |
| <b>Option</b>   | Body: <input type="checkbox"/> haste alloy C4 <input type="checkbox"/> titanium <input type="checkbox"/> others: _____<br>Ball: <input type="checkbox"/> zirkonium oxid <input type="checkbox"/> titanium 0,2% Pd <input type="checkbox"/> others: _____<br>Others: <input type="checkbox"/> spring washer nickel plated<br><input type="checkbox"/> o-Ring Viton / FEP lined<br><input type="checkbox"/> heating jacket <input type="checkbox"/> others: _____   |
| <b>Add-On Components</b>  | Bottle connection <input type="checkbox"/> Duran GL45 <input type="checkbox"/> Duran GL32<br><input type="checkbox"/> flange connection <input type="checkbox"/> others: _____<br><input type="checkbox"/> bajonet connection<br>Attachment: <input type="checkbox"/> protection case <input type="checkbox"/> others: _____  |
| <b>Accessories</b>  | Protection case: <input type="checkbox"/> standard <input type="checkbox"/> others: _____<br><input type="checkbox"/> 1" Venting<br><input type="checkbox"/> support (not for Bajonet locking)<br>Automation: <input type="checkbox"/> with counter <input type="checkbox"/> ON / OFF <input type="checkbox"/> time switch<br>Actuator: <input type="checkbox"/> multi-turn actuator (DAP 60 - 180°)<br><input type="checkbox"/> hand-lever<br><input type="checkbox"/> actuator    manufacturer : _____    type: _____<br>Sampling container: <input type="checkbox"/> sample bottle DIN 4796 GL45 Duran clear glass<br><input type="checkbox"/> will be supplied by customer<br><input type="checkbox"/> others: _____<br>Others: _____<br>_____<br>_____ |

Table 4 - Check list

**For your special requirements, please contact our technical sales department.**

## Pfeiffer Chemie-Armaturenbau GmbH

Hooghe Weg 41 • 47906 Kempen  
 Telefon: ++49 (0)2152 / 2005-0 • Telefax: ++49 (0)2152 / 1580  
 E-Mail: [vertrieb@pfeiffer-armaturen.com](mailto:vertrieb@pfeiffer-armaturen.com) • Internet: [www.pfeiffer-armaturen.com](http://www.pfeiffer-armaturen.com)

Specifications subject to change without notice