

# Operation, assembly and maintenance instructions for continuous sampling valve Series 27e



Fig. 1 - Sampling valve Series 27e

## 0. Introduction

These instructions are intended to support the user in the assembly and repair of sampling valves of the series 27e.

Technical details, as a result of the further development of the valves mentioned in these instructions are subject to modification. The text and illustrations do not necessarily display the scope of supply, or an eventual order of spare parts. Drawings and graphics are not to scale. Customer related special designs, which are not in accordance with our standard offer, are not shown.

The transfer of these instructions to third parties is only allowed with the written approval of Pfeiffer Chemie-Armaturenbau GmbH. All documents are protected according to the laws of the German Copyright Act.

The transmission and/or duplication of documents, even in abstracts, also the exploitation and communication of their content is not permitted, unless expressly granted.

Violations are an offence and liable to claims for damages. We reserve all rights for the exercise of industrial property rights.



The equipment may only be dismantled and disassembled by skilled staff, who are familiar with the assembly, the start-up and the operation of this product.

Skilled staff in the sense of these repair and assembly instructions are persons who, as a result of their training, knowledge, and experience, also their knowledge of the relevant standards, are able to judge the tasks assigned to them and are able to recognise possible dangers.

## 1. Design, operation and dimensions

Design, operation and dimensions, as well as all further technical details may be found in the **Data sheet** < TB 27d\_EN > for sampling valve Series 27d / Series 27e.

## 2. Installation, start-up and maintenance

Guidelines for the installation, start-up and maintenance can be found in the respective operating instructions for sampling valves.

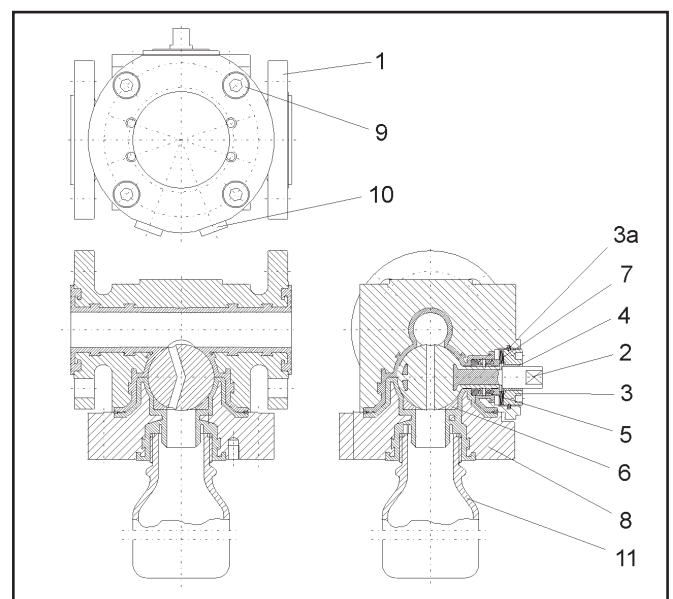

Fig. 2 - Sectional view of sampling valve series 27e => Parts list see Table 1 on page 2

# Sampling valve Series 27e

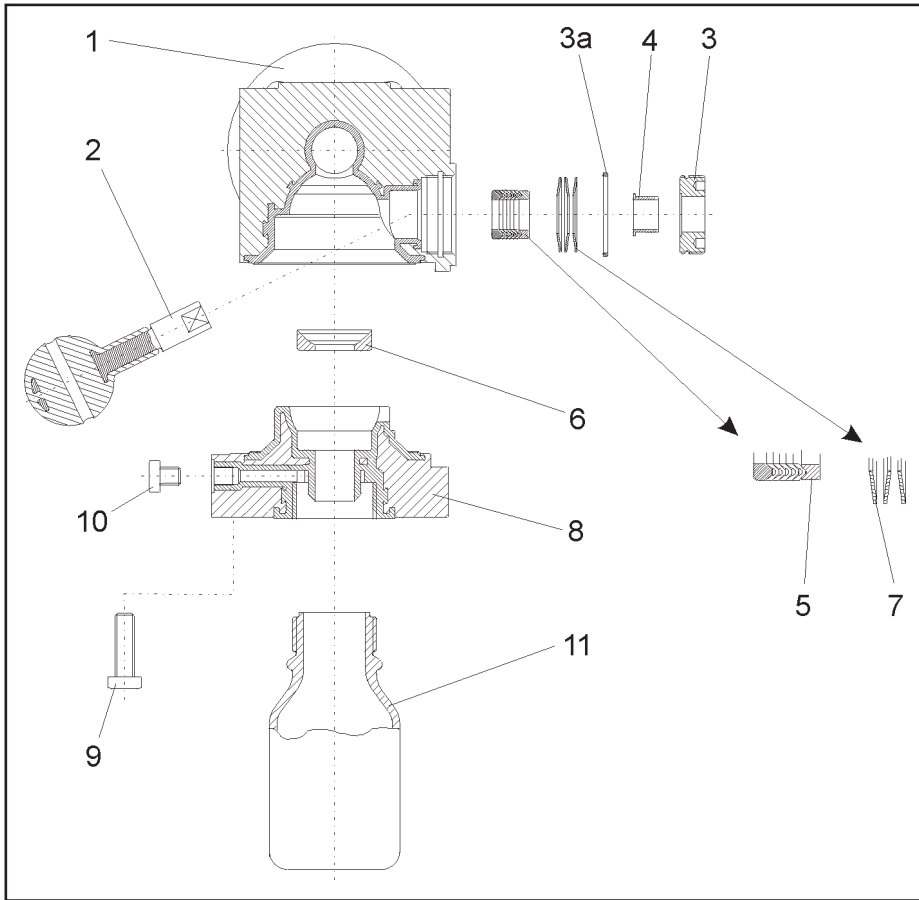

Fig. 3 - Explosion drawing series 27e

Pos.	Qty.	Description	Material
1	1	Main body	C22.8 / PFA
2	1	Ball	1.4021 / PTFE
3	1	Stuffing box	1.4305 / Peek
3a	1	Retaining ring	Peek
4	1	Bearing bush	PTFE with 25% carbon
5	1	V-ring packung	1.4305 / PTFE
6	1	Sealing seat	PTFE
7	1	Spring washer	1.8159 - Deltatone lined
8	1	Bonnet	St 52-3 / PFA
9	1	Screw	A2-70
10	2	Countersunk screws	PTFE
11	1	Sampling bottle	glass

Table 1 - Parts list

## 3. Assembling the sampling valve

### 3.1 Preparation for assembly

To assemble the sampling valve, clean all parts thoroughly, and lay them on a soft padding surface ( rubber mat. etc.) Take into consideration, that parts made of plastic are nearly always soft and sensitive, and that especially the sealing surfaces must not be damaged.



**Note:** The position and arrangement of the individual parts shown in the exploded drawing must be strictly adhered to on assembling the valve.

### 3.2 Initial assembly of bonnet for the support

Insert the sealing ring ( 6 ) onto the bonnet ( 8 ). Apply silicone grease (e.g. Wacker silicone grease 400 medium or equivalent) to the sealing area of ball.

### 3.3 Initial assembly of packing gland

Insert the bearing bush ( 4 ) into the packing gland ( 3 ).

### 3.4 Assembling the ball valve body

Place the body ( 1 ) with the sealing area of the ball facing upwards on a soft surface.

Apply silicone grease to the sealing area. Insert the ball ( 2 ) into the body.

Apply grease (e.g. Gleitmo 805 from Fuchs or equivalent) to the cheese head screws ( 9 )

Place the ready-assembled bonnet on the body and align over the cheese-head screws. Tighten the screws evenly in an alternating pattern.

Turn the body in such a way, that the shaft of the ball faces upwards and the opening to mount the packing is easily accessible.

Apply silicone grease to all the V-rings of the packing ( 5 ). First, insert the bottom V-ring into the body bore using a blunt piece of piping.

Following this, insert each V-ring separately, finishing with the stainless steel packing follower. Refer to the exploded drawing (Fig. 3) The peek ring is separated on one side, and inserted into the intended groove in the body.

Now the spring washers (7) can be inserted. For the exact arrangement of the spring washers, refer to the exploded drawing (Fig. 3)

Finally, using a special wrench, fit the ready-assembled packing gland into the body.

**The assembly of the sampling valve is now completed.**

## 4. Troubleshooting

Action to be taken in the event of a malfunction is described in the operating instructions for sampling valves. You can also contact Pfeiffer Chemie-Armaturenbau GmbH. directly if you require help.

## 5. Repairing the valve

### 5.1 Replacing the V-ring packing

Should the ball valve leak at the packing, the V-ring packing ( 5 ) must be replaced as follows:

- Use a special wrench to the packing gland ( 3 ) and remove it.
- Check the bearing bush ( 4 ) and retaining ring ( 3a ) for any damage, and if necessary replace with new parts.
- Remove the set of belleville spring washers ( 7 ).
- Take out the packing follower.
- Carefully remove the PTFE V-rings ( 5 ) out of the packing chamber of the valve body.
- Check the V-rings for damage, and in case of doubt, replace with new ones.
- Reassembling the valve
- Proceed in the reverse order to reassemble the valve. Refer to the instructions (section 3 ) for any missing details or descriptions.

### 5.2 Replacing the sealing ring and ball

If the ball does not shut-off tightly, remove the sealing ring (6) and ball ( 2 ) as described as follows, and check them.

- Removing the sealing ring.
  - Unscrew the cheese-head screws ( 9 )
  - Carefully lift off bonnet ( 8 )
  - Remove sealing ring ( 6 ), check it fo damage, and replace it if necessary.
- Removing the ball
  - Using a special wrench, undo the packing gland ( 3 ) and remove it.
  - Remove the set of belleville spring washers ( 7 )
  - Remove the packing follower.
  - Carefully remove the PTFE V-rings ( 5 ) from the packing chamber of the valve body.
  - The ball ( 2 ) is now accessible in the body, and can be carefully removed. Check the ball for damage and if necessary, replace it.
- Reassembling the valve
  - Proceed in the reverse order to reassemble the valve. Refer to the assembly instructions (section 3) for any missing details or descriptions.

## 6. Operating the sampling valve

### 6.1 Important general instructions



It may be necessary to clean the sampling chamber and the through bore after a sample has been taken, depending on the medium used. The operator must decide if this action is necessary.

- It is absolutely important, that before taking a sample, the sampling container (glass bottle etc.) adapted to the temperature of medium being taken!
- Safety precautions need to be taken when the medium temperature exceeds 60°C as a risk of scalding is possible.
- When taking samples, the general accident prevention regulations must be complied with at all times!

### 6.2 Sampling valve with „dead mans control“



- Screw on the sample bottle by hand as tightly as possible.
- Turn the hand-lever 90° until the bore is in the medium flow.
- Hold the lever in this position until the required amount of medium has been collected
- Turn back the handlever.
-  Do not release the hand lever abruptly while collecting the medium, as the automatic device will be activated, and the sampling will automatically stop.
- Unscrew the sample bottle and if necessary seal with a lid.

### 6.3 Sampling valve with „dead mans control“ and protective case



- Open protective case.
- Screw on the sample bottle by hand as tightly as possible
- Close protective case.
- Turn the handlever 90° until the bore is in the medium flow.
- Hold the handlever in this position until the required amount of media has been collected.
- Turn back the handle.
-  Do not release the hand-lever abruptly while the medium is being collected, as the automatic device will be activated, and the sampling will stop automatically.
- Open protective case, remove the sampling bottle, and if necessary seal bottle with a lid.
- Close the protective case.

# Sampling valve Series 27e

## 6.4 Sampling valve with „dead mans control“ and protective case and support



- Protective case.
- Pull down the support on the handlever.
- Place the sample bottle into the PTFE seat of the support.
- Guide the support upwards and close protective case
- Turn the handlever 90° until the bore is in the medium flow.
- Hold the handlever in this position until the required amount has been collected
- Turn back the handlever.



Do not release the handlever abruptly while the medium is being collected, as the automatic device will be activated, and the sampling will stop automaically.

- Open the protective case, guide the support downwards, remove the sample bottle, and if necessary seal bottle with a lid.

## 6.5 Sampling valve with automatic 90° rotary actuator and protective case

### 6.5.1 general automated sampling

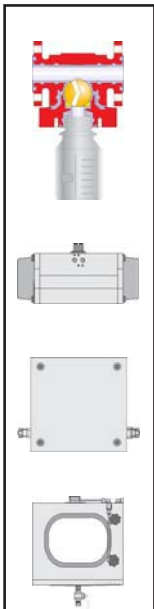

- Open protective case .
- Screw on sample bottle by hand as tightly as possible.
- Close protective case.
- Open the air supply valve at the automation unit
- **Attention:** Before operating, refer to the respective operating instructions for the automated unit, which can be found in **Section 7** (Operating the automation unit)
- Close the air supply valve at the automation unit
- Open the protective case, remove the sample bottle, and if necessary seal the bottle with a lid.
- Close the protective case.

### 6.5.2 automated sampling with back pressure indication

- Operating this type of sampling is identical to the operating instructions **Section 6.5.1**
- In addition to the above mentioned version, the following function is included:
  - The automation switches off automatically, and no further sample can be taken when the level in the glass bottle reaches the back pressure tube.



When attaching the bottle, avoid at all time bending the back pressure tube!

### 6.5.3 automated sampling with pneumatic barrier

- Operating this type of sampling is identical to the operating instructions in **Section 6.5.1**
- In addition to the above mentioned version, the following function is included:
  - The automation switches off automatically, and no further sample can be taken when the protective case is opened during the sampling procedure.

## 6.6 Sampling valve with automated 90° rotary actuator and protective case with support

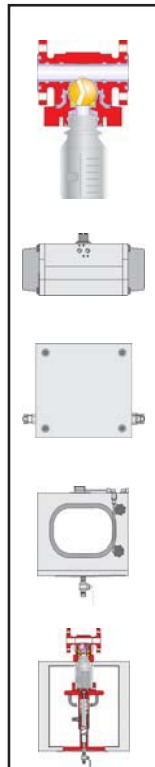

### 6.6.1 general automatic sampling

- Open protective case.
- Pull down the support on the handlever.
- Place the sample bottle in the PTFE seat of the support.
- Guide the support upwards.
- Close the protective case.
- Open the air supply valve at the automation unit
- **Attention:** Before operating, refer to the respective operating instructions for automated unit, which can be found in **Section 7** (operating the automation unit).
- Close the air supply valve at the automation unit.
- Open the protective case, guide the support downwards, remove sample bottle, and if necessary seal the bottle with a lid.
- Close the protective case.

### 6.6.2 automatic sampling with back pressure indication

- Operating this type of sampling is identical to the operating instructions described in **Section 6.6.1**
- In addition to the above mentioned version, the following function is included:
  - The automation switches off automatically, and no further sample can be taken, when the sample level in the bottle reaches the back pressure tube!



When attaching the bottle, avoid at all times bending the back pressure tube!

### 6.6.3 automatic sampling with pneumatic barrier

- Operation for this type of sampling is identical to the operating instructions described in **Section 6.6.1**
- In addition to the above mentioned version, the following function is included:
  - The automation switches off automatically and no further sample can be taken when the protective case is opened during the sampling procedure.

## 7. Operation of automation units

### 7.1 Automation with „ON/OFF“ - Switch



**Note:** The timing for filling the actuator with air are pre-set timings, which were set before leaving our works. Any alterations to these settings may only be made after first consulting Pfeiffer Chemie-Armaturenbau!

- Press the start button. Continue to press button until the required amount of medium has been collected in the bottle.



If the button is released during or at the end of sampling, the „dead mans control“ becomes activated, and the sampling is switched off automatically.

### 7.2 Automation with counter



**Note:** The pulse timing and interval times between actuation cycles, and the timing for filling the actuator with air or venting it, are pre-set timings which were set before leaving our works. Any alterations to these settings, may only be made after first consulting Pfeiffer Chemie-Armaturenbau GmbH!

- Set the number of actuating cycles at the counter.



**Attention:** The selected number of actuating cycles must correspond to the volume of the sample bottle.

- Press the start button. The pre-selected number of actuating cycles to take samples are performed.
- The sampling finishes automatically after the selected number of actuating cycles have been completed.



**Attention!** In the event of an operation fault, press the emergency button immediately.

### 7.3 Automation with counter and timer switch

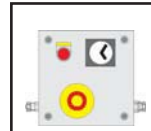

**Note:** The pulse timing of actuation and the timing for filling the actuator with air or venting it, are pre-set timings, which were set before leaving our works. Any alterations to these settings may only be made after first consulting with Pfeiffer Chemie-Armaturenbau GmbH!

- The required interval between each actuation cycle can be set at the timer switch.

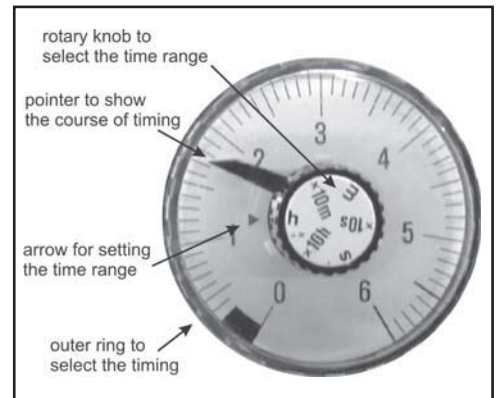

Fig. 4 - Samsomatic - Time switch 3970

- Select time range. The switch-over range is selected with the rotary knob located in the middle of the timer, by setting the dial arrow to the required range.

Selection	Time range
s	0,3 to 6 seconds
x10s	3 to 60 seconds
m	0,3 to 6 minutes
x10m	3 to 60 minutes
h	0,3 to 6 hours
x10h	3 to 60 hours

Table 2 - Time ranges

- Determine which timing you require. The required cycle time can be set by turning the outer ring. A pointer indicates the cycle time.

- Set the number of actuation cycles at the counter.



**Attention:** The selected number of actuating cycles must correspond to the volume of the sample bottle.

## Sampling valve Series 27e

- Press the start button.  
The pre-selected number of actuating cycles to take samples, together with the pre-selected intervals are performed.
- The sampling finishes automatically after the selected number of actuating cycles have been completed.



**Attention!** In the event of an operation fault, press the emergency button.

## 8. Circuit diagram

Circuit diagram for the automation unit.

Should you have any queries, please contact Pfeiffer Chemie-Armaturenbau GmbH

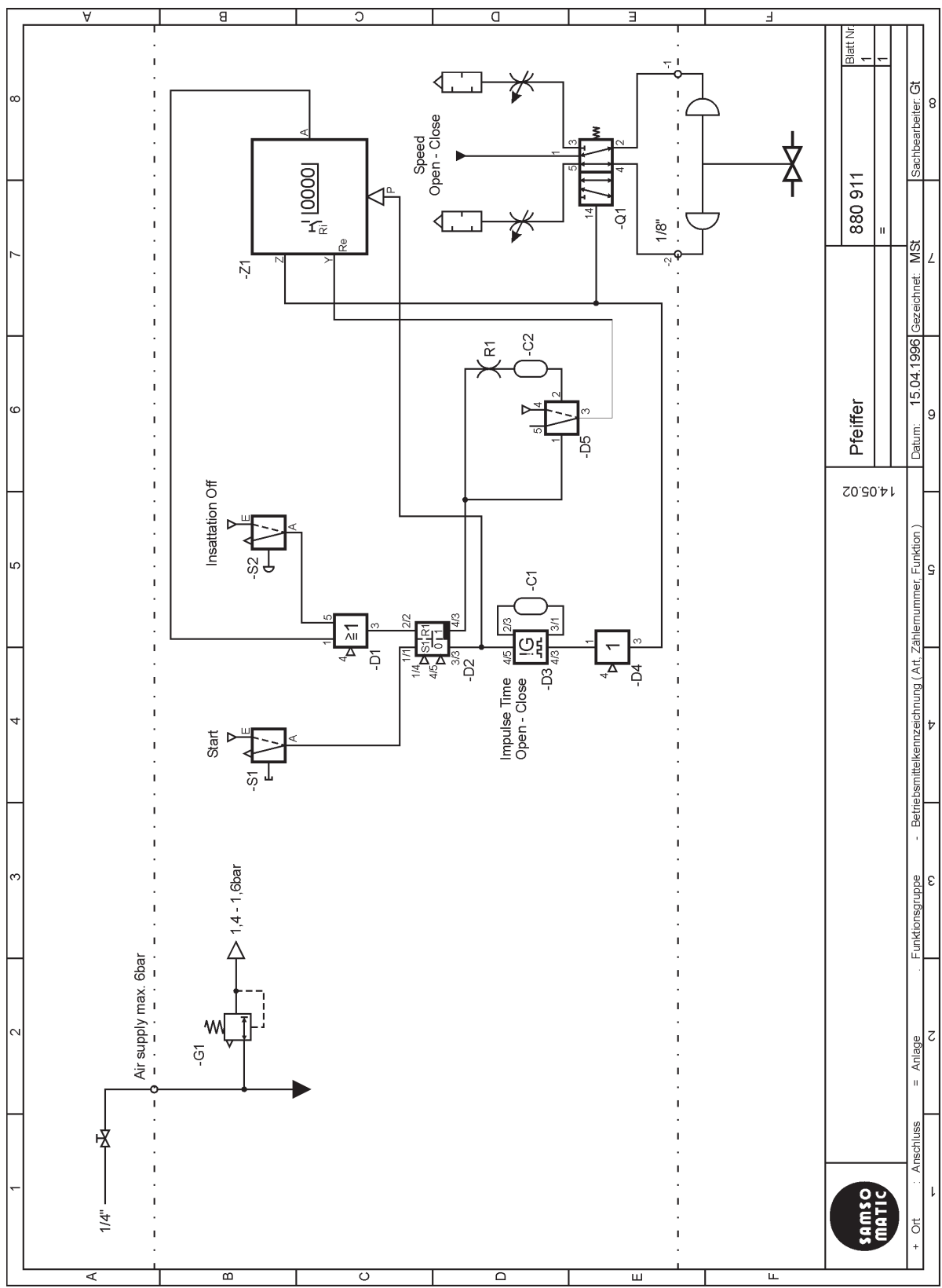

Fig. 5 - Circuit diagram



Pfeiffer	880 911	Blatt Nr 1	1	Sachbearbeiter: Gt ∞
14.05.02	=			
Datum: 15.04.1996 Gezeichnet: MST				
Funktionsgruppe - Betriebsmittelkennzeichnung (Art, Zahlennummer, Funktion)				
+ Ort	= Anlage			

## 9. Customer inquiries

Details as per the check list for repairs and inquiries.

<b>Check list for repairs and inquiries for the sampling valve series 27e</b>	
<b>General</b>	Commission number: ( embossed on the type plate _____ Kunde: _____ Telephone: _____ Fax: _____
<b>Medium</b>	Medium: _____ Temperature: _____ °C      op pressure: _____ bar Viscosity: <input type="checkbox"/> like water <input type="checkbox"/> like honey <input type="checkbox"/> like oil <input type="checkbox"/> others: _____ Characteristic: <input type="checkbox"/> toxic <input type="checkbox"/> caustic <input type="checkbox"/> corrosiveness <input type="checkbox"/> abrasiv <input type="checkbox"/> foaming <input type="checkbox"/> others: _____
<b>Valve</b>	Nominal size: <input type="checkbox"/> DN 25 <input type="checkbox"/> DN 50
<b>Option</b>	Ball: <input type="checkbox"/> haste alloy C4 <input type="checkbox"/> titanium <input type="checkbox"/> others: _____ <input type="checkbox"/> zirkonium oxid <input type="checkbox"/> titanium 0,2% Pd others: <input type="checkbox"/> heating jacket <input type="checkbox"/> others: _____
<b>Add-on Components:</b>	Bottle connection <input type="checkbox"/> Duran GL45 <input type="checkbox"/> Duran GL32 <input type="checkbox"/> flange connection <input type="checkbox"/> others: _____ <input type="checkbox"/> bajonet connection Attachment: <input type="checkbox"/> protection case <input type="checkbox"/> others: _____
<b>Accessories</b>	Schutzkasten: <input type="checkbox"/> Standard <input type="checkbox"/> 1" venting <input type="checkbox"/> others: _____ <input type="checkbox"/> support (not for bajonet locking) Automation: <input type="checkbox"/> with counter <input type="checkbox"/> ON / OFF <input type="checkbox"/> time switch Actuator: <input type="checkbox"/> multi turn actuator SRP100 - 90° <input type="checkbox"/> dead mans control <input type="checkbox"/> actuator      Manufacturer: _____ Type: _____ Sampling container <input type="checkbox"/> sample bottle DIN 4796 GL45 Duran clear glass <input type="checkbox"/> will be supplied by customer <input type="checkbox"/> others: _____ Others: _____ _____ _____

Table 3 - Check list

For your special requirements, please contact our technical sales department.

## Pfeiffer Chemie-Armaturenbau GmbH

Hooghe Weg 41 • 47906 Kempen  
 Telephone: 02152 / 2005-0 • Fax: 02152 / 1580  
 E-Mail: [vertrieb@pfeiffer-armaturen.com](mailto:vertrieb@pfeiffer-armaturen.com) • Internet: [www.pfeiffer-armaturen.com](http://www.pfeiffer-armaturen.com)

Specifications are subject to change without notice