

Operating, assembly and maintenance instructions for continuous sampling valve Series 27c

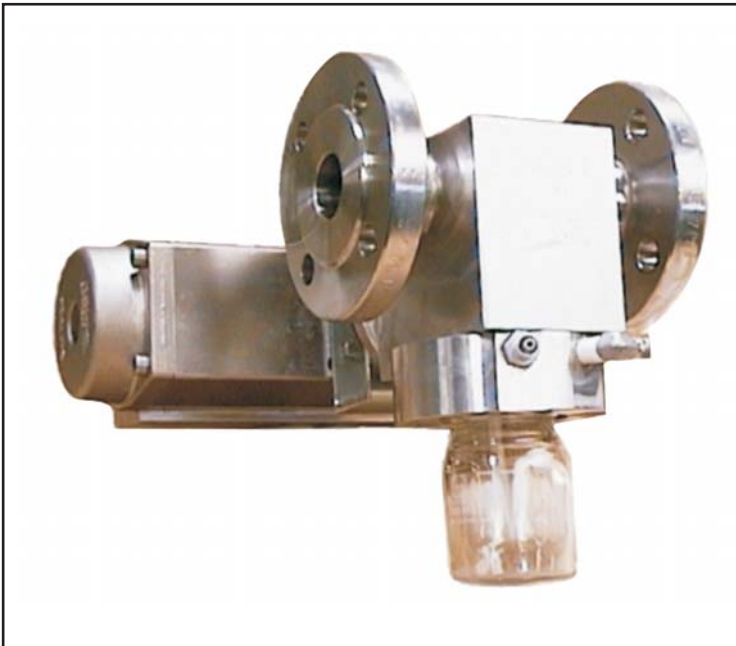

Fig. 1 - Sampling valve Series 27c



The equipment may only be dismantled and disassembled by skilled staff who are familiar with the assembly, the start-up and the operation of this product.

Skilled staff in the sense of these repair and assembly instructions are persons who, as a result of their training, knowledge, and experience, also their knowledge of the relevant standards, are able to judge the tasks assigned to them and are able to recognise possible dangers.

1. Design, operation and dimensions

Design, operation and dimensions, as well as all further technical details may be found in the **Data sheet < TB 27a_EN >** for samplers **series 27a / series 27c**.

2. Installation, start-up and maintenance

Guidelines for the installation, start-up and maintenance can be found in the respective operating instructions for sampling valves.

0. Introduction

These instructions are intended to support the user in the assembly and repair of sampling valves of the series 27c.

Technical details, as a result of the further development of the valves mentioned in these instructions, are subject to modification. The text and illustrations do not necessarily display the scope of supply, or an eventual order of spare parts. Drawings and graphics are not to scale. Customer related special designs, which are not in accordance with our standard offer, are not shown.

The transfer of these instructions to third parties is only allowed with the written approval of Pfeiffer Chemie Armaturenbau GmbH. All documents are protected according to the laws of the German Copyright Act.

The transmission and/or duplication of documents, even in abstracts, also the exploitation and communication of their content is not permitted, unless expressly granted.

Violations are an offence and liable to claims for damages. We reserve all rights for the exercise of industrial property rights.

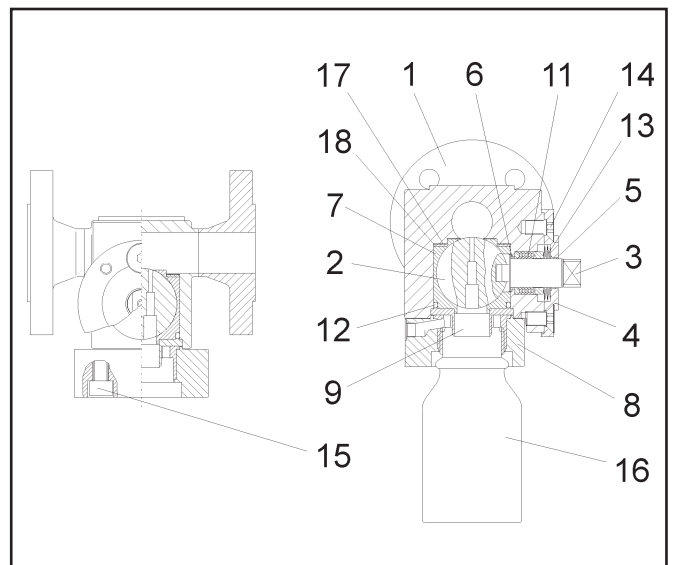

Sampling valve Series 27c

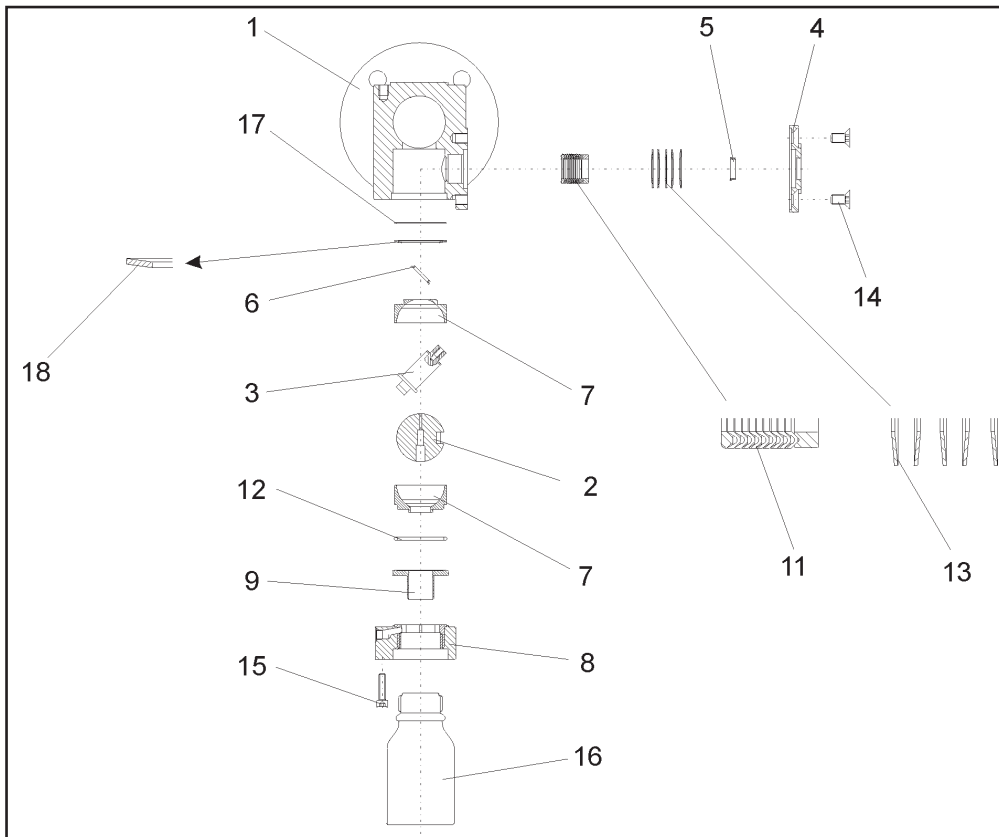

Fig. 3 - Exploded drawing of a sampling valve Series 27c

Take into consideration, that parts made of plastic are nearly always soft and sensitive, and that especially the sealing surfaces must not be damaged.



Note: The position and arrangement of the individual parts shown in the exploded drawing must be strictly adhered to on assembling the valve.

3.2 Assembly of the Sampling valve

Clamp the body (1) with the sealing area of the ball facing upwards in a vice, so that it is accessible for assembly.

The sealing ring (17) and the spring washer (18) are inserted into the body. For the exact positioning of the spring washer, refer to the explosion drawing (Bild 3). The bearing bush (6) is pressed into its intended

Pos.	Qty.	Description	Material
1	1	Main body	1.4571
2	1	Ball	1.4571
3	1	Stem	1.4571
4	1	Stuffing box	1.4571
5	1	Bearing bush	PTFE with 25% carbon
6	1	Bearing bush	PTFE mit 25% glass
7	1	Sealing seat	TFM
11	1	V-ring packing	1.4305 / PTFE
12	1	O-ring	Viton
13	1	Spring washer set	1.8159 - Deltatone lined
14	2	Countersunk screws	A2-70
17	1	Sealing ring	PTFE
18	1	Spring washer	1.4310
8	1	Bonnet with sleeve	1.4571/PTFE-40% glass
9	1	Running sleeve	1.4571
15	4	Cheese-head screws	A2-70
16	1	Sampling bottle	glass

Table 1 - Parts list

position, for the subsequent locating of the stem. After the sealing element lower part (7) has been inserted, the stem (3) is inserted into the pre-assembled bearing bush (6). The ball (2) with the slot is pressed onto the stem, and with evenly applied pressure, the stem is rotated and pressed until it finally sits in the sealing shell. Finally the ball is turned 90° so that the sampling bore is facing forward. The sealing element, top part (7) is inserted, then the ball is rotated slowly, so that the sealing element locates cleanly into position.

The O-ring (12) and running sleeve (9) are placed on the sealing element. Apply grease to the cheese-head screws (15) (e.g. Gleitmo greese 805, Fuchs or equivalent). The bonnet with insert (8) is mounted, and aligned with the cheese head screws. Tighten the screws evenly, and in alternating pattern.

Now turn the body, 90° gedreht, and again clamp in the vice, so that the stuffing box area is facing upwards, accessible for further assembly.

The PTFE -V-ring packing (11) is inserted in the body bore in the following order PTFE-bottom ring, PTFE-V-rings and steel V-ring. Following this, insert the spring washer (13). For exact positioning and locating of the V-ring packing and spring washers, refer to the explosion drawing (Bild 3) Apply grease to the countersunk screws (14) The stuffing box. (4) and the pre-assembled bearing sleeve (5) are mounted and aligned with the countersunk screws.

Next, tighten the screws evenly and in alternating pattern.

The assembly of the sampling valve is now completed.

3. Assembling the sampling valve

3.1 Preparation for assembly

To assemble the sampling valve, clean all parts thoroughly, and lay them on a soft padding surface (rubber mat, etc.)

4. Trouble shooting

Action to be taken in the event of a malfunction is described in the operating instructions for sampling valves. You can also contact Pfeiffer Chemie-Armaturenbau GmbH directly if you require help.

5. Repairing the ball valve

5.1 Replacing the V-ring packing

Should the ball valve leak at the packing, the V-ring packing (11) must be replaced as follows:

- Loosen and remove the countersunk screws (14).
 - Take off stuffing box flange (4).
 - Check the bearing bush (5) for damage, replace if necessary.
 - Remove the spring washers (13).
 - Remove the retainer ring from the V-ring packing.
 - Carefully remove the PTFE - V-rings (11) from the packing chamber of the valve body.
 - Check the V-rings for damage, and if in doubt replace with new ones.
 - Reassembling the valve
 - To reassemble the valve, proceed in reverse order to the instructions mentioned above.
- For any missing descriptions or details, refer to the assembly instructions (Section 3).

5.2 Replacing the sealing rings and ball

If the ball does not shut-off tightly and leaks, the sealing ring (7) and the ball (2) must be removed and checked as follows:

- Dismantling the first sealing ring
 - Loosen and remove the cheese-head screws (15).
 - Carefully remove bonnet (8) and running sleeve (9)
 - Check O-ring (12) for damage, and if necessary replace it.
 - Remove the sealing ring (7) and check for damage, if required replace with a new one.
 - Removing the ball
 - The ball (2) is now accessible in the body, and can now be carefully removed. Check the ball for damage, if necessary replace with a new ball.
 - Dismantling the second sealing ring
 - Remove the stem (3) and bearing bush (6) from the main body (1).
 - Remove the sealing ring (7) check for damage and if necessary replace it.
 - Reassembling the valve
 - To reassemble the valve, proceed in reverse order to instructions mentioned above.
- For any missing descriptions or details, refer to the assembly instructions in (Section 3)

5.3 Dismantling the stem

In case of damage, or in the course of replacing the sealing ring, it may be necessary to dismantle the stem (3) as follows:

- Dismantling the V-ring packing
 - Loosen and remove the countersunk screws (14).
 - Take off the stuffing box flange (4).
 - Remove the bearing sleeve (5) and spring washers (13).
 - Remove the retainer ring of the V-ring packing.
 - Now, carefully remove the PTFE - V-rings of the V-ring packing (11) from the packing chamber of the body.
 - Dismantling the body
 - Loosen, and remove the cheese-head screws (15).
 - Carefully take off the bonnet (8) and running sleeve (9).
 - Remove the O-ring (12) and sealing ring (7).
 - Removing the ball
 - The ball (2) is now accessible in the body, and can be carefully removed.
 - Dismantling the stem
 - Remove the stem (3) and bearing bush (6) from the body (1).
 - The stem (5) and the bearing bush (7) can now be checked for damage, and if necessary be replaced.
 - Reassembling the valve
 - To reassemble the valve, proceed in reverse order to the instructions above.
- For any missing descriptions, or details, refer to the assembly instructions in (Section 3)

6. Operating the sampling valve

6.1 Important general instructions



It may be necessary to clean the sampling chamber and blind hole after a sample has been taken. The operator must decide when this is necessary.

- It is absolutely important, that before taking a sample, the sampling container (glass bottle etc.) is adapted to the temperature of the medium being taken.
- Safety precautions must be taken when the medium temperature exceeds 60° possible risk of scalding.
- When taking samples, the general accident prevention regulations must be complied with at all times.

6.2 Sampling valve with „dead mans control“



- Screw on the sample bottle by hand as tightly as possible.
 - Turn handle lever 90° until the bore is in the medium flow.
 - Hold the lever in this position until the required amount of medium has been collected.
 - Turn back the handle lever.
-  Do not release the hand lever abruptly while the medium is being collected, as the automatic device will be activated and the sampling will automatically stop.
- Unscrew the sample bottle and if necessary, seal with a lid.

Sampling valve Series 27c

6.3 Sampling valve with „dead mans control“ and protective case



- Open protective case.
 - Screw on the sample bottle by hand as tightly as possible.
 - Close protective case.
 - Turn the handel 90° until the bore is in the medium flow.
 - Hold in this position until the required amount of media has been collected, .
 - Turn back the handel .
-  Do not release the hand-lever abruptly while the medium is being collected, as the automatic safety device will be activated and the sampling will automatically stop.
- Open protective case and remove the sampling bottle, and if necessary seal bottle with a lid.
 - Close the protective case.

6.4 Sampling valve with „dead mans control“ and protective case and support



- Open protective case.
 - Pull down the support on the handlever
 - Place the sample bottle into the PTFE-seat of the support.
 - Guide the support upwards and close protective case.
 - Turn the handlever 90° until the bore is in the medium flow.
 - Hold the handlever in this position until the required amount has been collected
 - Turn back the handlever.
-  Do not release the handlever abruptly while the medium is being collected as the automatic safety device will be activated, and the sampling will automatically stop.
- Open the protective case, guide the support downwards remove the sample bottle, and if necessary seal bottle with a lid.
 - Close the protective case.

6.5 Sampling valve with automatic 90° rotary actuator and protective case



6.5.1 General automated sampling

- Open protective case.
- Screw on sample bottle by hand as tightly as possible
- Close protective case.
- Open the air supply valve at the automation unit.
- **Attention:** Before operating, refer to the respective operating instructions for the automated unit, which can be found in **Section 7** (Operating the automation unit).
- Close the air supply valve at the automation unit.
- Open the protective case, remove the sample bottle, and if necessary seal the bottle with a lid.
- Close the protective case.

6.5.2 Automated sampling with back pressure indication

- Operating this type of sampling is identical to the operating instructions **Section 6.5.1**
- In addition to the above mentioned version, the following function is included:
 - The automation switches off automatically and no further sample can be taken when the sample level in the glass bottle reaches the back pressure tube.



When attaching the bottle, avoid at all times bending the back pressure tube!

6.5.3 Automatic sampling with pneumatic barrier

- Operating this type of sampling is identical to the operating instructions in **Section 6.5.1**
- In addition to the above mentioned version, the following function is included:
 - The automation switches off automatically, and no further sample can be taken when the protective case is opened during the sampling procedure.

6.6 Sampling valve with automated 90° rotary actuator and protective case with support

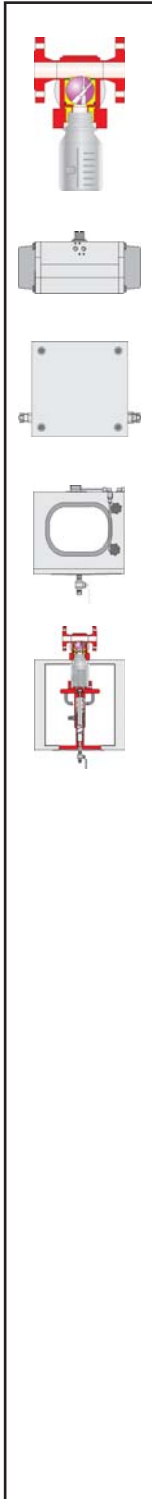

6.6.1 General automatic sampling

- Open protective case.
- Pull down the support on the handlever.
- Place the sample bottle in the PTFE - seat of the support.
- Guide the support upwards.
- Close the protective case.
- Open the air supply valve at the automation unit.
- **Attention:** Before operating, refer to the respective operating instructions for automated unit, which can be found in **Section 7** (Operating the automation unit)
- Close the air supply valve at the automation unit.
- Open the protective case, guide the support downwards, remove sample bottle, and if necessary seal the bottle with a lid.
- Close the protective case.

6.6.2 Automatic sampling with back pressure indication

- Operating this type of sampling is identical to the operating instructions in **Section 6.6.1**
- In addition to the above mentioned version, the following function is included:
 - The automation switches off automatically, and no further sample can be taken, when the sample level in the bottle reaches the back pressure tube!



6.6.3 Automatic sampling with pneumatic barrier

- Operation for this type of sampling is identical to the operating instructions described in **Section 6.6.1**
- In addition to the above mentioned version, the following function is included:

The automation switches off automaitally and no further sample can be taken when the protective case is opened during the sampling procedure.

7. Operation of automation units

7.1 Automation with „ON/OFF“ - Switch



Note: The timing for filling the actuator with air or venting it are pre-set timings which were set before leaving our works. Any alterations to these settings may only be made after first consulting Pfeiffer Chemie-Armaturenbau GmbH!

- Press the start button. Continue to press button until the required amount of medium has been collected in the bottle.



If the button is released during or at the end of sampling, the „dead mans control“ becomes active, and the sampling is switched off automatically.

7.2 Automation with counter



Note: The pulse timing and interval times between actuation cycles, and the timing for filling the actuator with air or venting it are pre-set timings which were set before leaving our works. Any alterations to these settings, may only be made after first consulting Pfeiffer Chemie-Armaturenbau GmbH!

- Set the number of actuating cycles at the counter.



Attention: The selected number of actuating cycles must correspond to the volume of the sample bottle.

- Press the start button. The pre-selected number of actuating cycles to take samples are performed.
- The sampling finishes automatically after the selected number of actuating cycles have been completed.



Attention! In the event of an operation fault, press the emergency button immediately.

Sampling valve Series 27c

7.3 Automation with counter and timer switch



Note: The pulse timing of actuation and the timing for filling the actuator with air or venting it are pre-set timings, which were set before leaving our works. Any alterations to these settings may only be made after first consulting Pfeiffer Chemie-Armaturenbau GmbH!

- The required interval between each actuation cycle can be set at the timer switch.

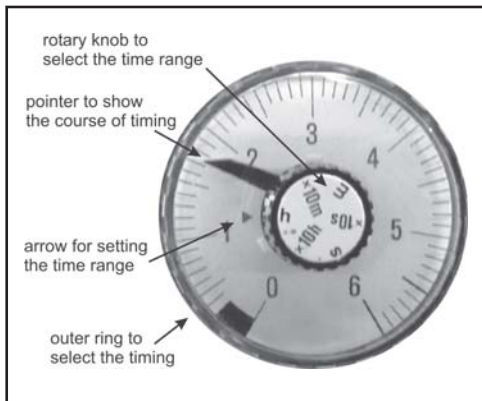

Fig. 4 - Samsomatic - Time switch 3970

- Select time range
The switch-over range is selected with the rotary knob located in the middle of the timer. By setting the dial arrow to the required range.

Selection	Time range
s	0,3 to 6 seconds
x10s	3 to 60 seconds
m	0,3 to 6 minutes
x10m	3 to 60 minutes
h	0,3 to 6 hours
x10h	3 to 60 hours

Table 2 - Time ranges

- Determine which timing you require. The required cycle time can be set by turning the outer ring. A pointer indicates the cycle time
- Set the number of actuation cycles at the counter.



Attention: The selected number of actuating cycles must correspond to the volume of the sample bottle.

- Press the start button. The pre-selected number of actuating cycles to take samples, together with the pre-selected intervals are performed.
- The sampling finishes automatically after the selected number of actuating cycles have been completed.



Attention! In the event of an operation fault, press the emergency button.

8. Circuit diagram

Circuit diagram for the automation unit.

Should you have any queries, please contact Pfeiffer Chemie-Armaturenbau GmbH

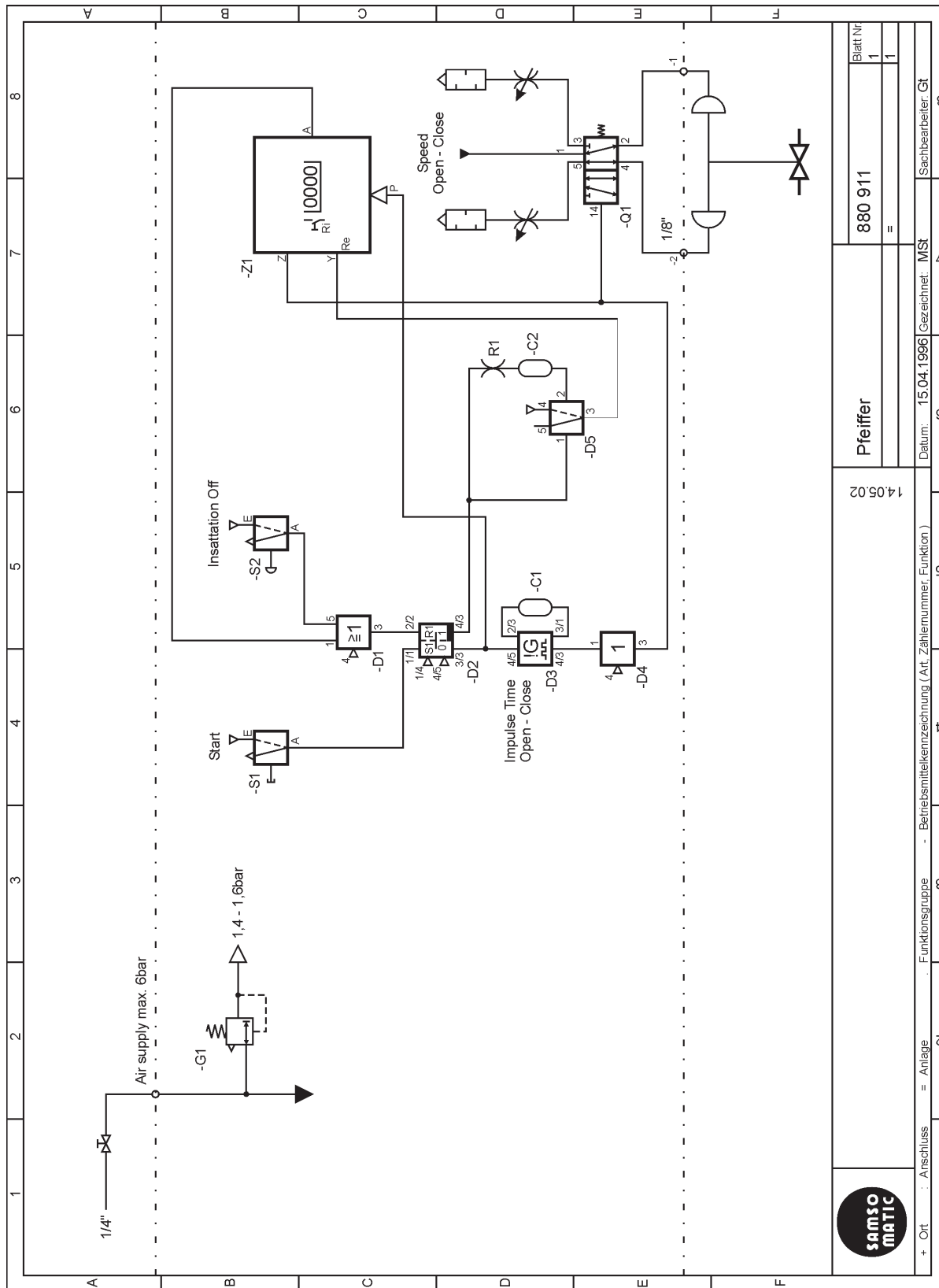

Fig 5 - Circuit diagram



+ Ort	= Anschluss	= Anlage	= Funktionsgruppe	= Betriebsmittelkennzeichnung (Art, Zahlenummer, Funktion)	= Gezeichnet: MST	= Sachbearbeiter: Gt
					Datum: 15.04.1996	880 911
						Pfeiffer
				14.05.02		880 911
						=
						1
						1
						Bleat N°r

9. Customer inquiries

Details as per the check list for repairs and inquiries.

Check list for repairs and inquiries for the sampling valve series 27c	
General	Commission number: (embossed on the type plate _____) Kunde: _____ Telephone: _____ Fax: _____
Medium	Medium: _____ Temperature: _____ °C op pressure: _____ bar Viscosity: <input type="checkbox"/> like water <input type="checkbox"/> like honey <input type="checkbox"/> like oil <input type="checkbox"/> others: _____ Characteristic: <input type="checkbox"/> toxic <input type="checkbox"/> caustic <input type="checkbox"/> corrosiveness <input type="checkbox"/> abrasiv <input type="checkbox"/> foaming <input type="checkbox"/> others: _____
Valve	Nominal size: <input type="checkbox"/> DN 25 <input type="checkbox"/> DN 50 <input type="checkbox"/> DN 80 <input type="checkbox"/> DN 100
Option	Body: <input type="checkbox"/> haste alloy C4 <input type="checkbox"/> titanium <input type="checkbox"/> others: _____ Ball: <input type="checkbox"/> zirkonium oxid <input type="checkbox"/> titanium 0,2% Pd <input type="checkbox"/> others: _____ others: <input type="checkbox"/> spring washer nickel plated <input type="checkbox"/> O-ring Viton / FEP lined <input type="checkbox"/> heating jacket <input type="checkbox"/> others: _____
Add-on Components	Bottle connection: <input type="checkbox"/> Duran GL45 <input type="checkbox"/> Duran GL32 <input type="checkbox"/> flange connection <input type="checkbox"/> others: _____ <input type="checkbox"/> bajonet connection Attachment: <input type="checkbox"/> protection case <input type="checkbox"/> others: _____
Accessories	Schutzkasten: <input type="checkbox"/> Standard <input type="checkbox"/> 1" venting <input type="checkbox"/> others: _____ <input type="checkbox"/> support (not for bajonet locking) Automation: <input type="checkbox"/> with counter <input type="checkbox"/> ON / OFF <input type="checkbox"/> time switch Actuator: <input type="checkbox"/> multi turn actuator SRP100 - 90° <input type="checkbox"/> dead mans control <input type="checkbox"/> actuator Manufacturer: _____ Type: _____ Sampling container <input type="checkbox"/> sample bottle DIN 4796 GL45 Duran clear glass <input type="checkbox"/> will be supplied by customer <input type="checkbox"/> others: _____ Others: _____ _____ _____

Table 3 - Check list

For your special requirements, please contact our technical sales department.

Pfeiffer Chemie-Armaturenbau GmbH

Hooghe Weg 41 • 47906 Kempen • Germany

Phone: +49 2152 - 2005-0 • Fax: +49 2152 - 1580

E-Mail: vertrieb@pfeiffer-armaturen.com • Internet: www.pfeiffer-armaturen.com

Specifications are subject to change without notice