



# TRANSLATION

## Declaration of Conformity as per Directive 2014/68/EU

The manufacturer	<b>Pfeiffer Chemie-Armaturenbau GmbH, 47906 Kempen, Germany</b>
declares that:	<b>Continuous, inline sampling valves BR27f, with packing</b> <ul style="list-style-type: none"> <li>• <b>Operate with either; Star lever, or dead man's control</b></li> </ul>
<ol style="list-style-type: none"> <li>1. The valves are pressure accessories within the meaning of the Pressure Equipment Directive 2014/68/EU and conform with the requirements of this Directive,</li> <li>2. They may only be operated observing the operating instructions &lt;BA27f-02&gt; delivered together with the valve.</li> </ol>	

*Applied standards:*

<b>AD 2000 Regulations DIN EN ISO 4796</b>	Regulations for pressurised valve body parts Laboratory glassware
--	--

*Type designation and technical features:*

Pfeiffer data sheets <TB27f> <i>NOTE: This Manufacturer's Declaration applies to all valve types listed in this catalogue.</i>
---

*Applied conformity assessment procedure:*

<b>Conforming to Annex III of the Pressure Equipment Directive 2014/68/EU, Module H</b>
---

*Name of notified body:*

*Identification number of the notified body:*

<b>TÜV Anlagentechnik GmbH</b> Am Grauen Stein 51101 Köln Germany	<b>0035</b>
--	-------------

These Declarations become invalid when modifications are made to the sampling valves and/or assemblies that affect the technical data of the sampling valve or the <Intended use> described in section 1 of the operating instructions, and considerably change the valve or an assembly delivered with it.

Kempen, 21. September 2017

Marcus Miertz, Chief Executive Officer

Stefan Czayka, IMS Representative

# **Operating instructions**

## **Continuous inline sampling valve**

### **Manually operated**

#### **Contents**

<b>0.</b>	<b>Introduction</b>	<b>3</b>
<b>1.</b>	<b>Intended use</b>	<b>3</b>
<b>2.</b>	<b>Safety instructions</b>	<b>3</b>
2.1	General safety instructions	3
2.2	Safety instructions for the operator	4
2.3	Particular hazards	5
2.4	Designation of the sampling valve	5
<b>3.</b>	<b>Transport and storage</b>	<b>6</b>
<b>4.</b>	<b>Installation in the pipeline</b>	<b>6</b>
4.1	General	6
4.2	Installation instructions	6
4.3	Attachment of an additionally supplied holding fixture for sampling bottles	7
<b>5.</b>	<b>Pressure check in pipeline section</b>	<b>7</b>
<b>6.</b>	<b>Standard operation and maintenance</b>	<b>7</b>
6.1	Sample bottle fixture	7
6.2	Sampling valve	7
6.3	Manual operation	7
<b>7.</b>	<b>Troubleshooting</b>	<b>8</b>
<b>8.</b>	<b>Further information</b>	<b>8</b>

## 0. Introduction

These instructions are designed to assist the user during installation, operation and maintenance of sampling valves from the BR27f.

 <b>Note</b>	<p>The use of sampling valves involves certain risks. The WARNING and CAUTION notes must be strictly adhered to. <b>Otherwise this may lead to personal injury and equipment damage</b> and the manufacturer's warranty may become void. Please contact the manufacturer if you have any queries, see section 8 for contact address.</p>
--	--

## 1. Intended use

This continuous sampling valve is exclusively intended for taking samples of liquid media from the pipeline in restricted quantities filled in a sufficiently sturdy sample bottle. The following conditions must be fulfilled before the valve can be taken into service:

- ⇒ The valve must be installed in a pipeline with flange connections.
- ⇒ A sample bottle must be attached underneath the sampling valve.
- ⇒ The permissible pressure and temperature ranges may not be exceeded.

The connection and holding fixture for the sample bottle must be specified beforehand by the customer. The manufacturer has developed various fixtures for this purpose.

The permissible pressure and temperature ranges for these sampling valves are specified in the data sheets <TB27f>.

 <b>Danger</b>	<p>Do not operate a sampling valve when its permissible pressure/temperature rating is not sized for the operating conditions specified in the data sheets &lt;TB27f&gt;.</p> <p><b>Failure to follow these safety precautions may result in personal injury and can damage equipment installed in the pipeline.</b></p>
--	--

### Interpretation of declaration to the Directive 2014/34/EU

 <b>Note</b>	<p>Pfeiffer valves have no own potential ignition source after testing the hazardous ignition in acc. to DIN EN 13463-1. Therefore Pfeiffer valves do not come under the directive 2014/34/EU.</p> <p><b>Relating to this directive a CE-marking is not permissible.</b> The valve could be incorporated into potential compensation of plants independent of the directive, valid for metallic parts in hazardous areas.</p>
--	---

- ⇒ The following conditions are assumed:
  - The operation of the valve, in particular, attaching the sample bottle to the valve, may only be performed by experienced and trained personnel who can recognise and react to any possible dangers that could be caused by leaking media.
  - The supplementary instructions for the holding fixture for the sample bottle are observed.
  - The instructions in section 2 <Safety instructions> are observed.
- ⇒ Parts subject to wear are not covered by the warranty.

## 2. Safety instructions

### 2.1 General safety instructions



For sampling valves, the same safety regulations apply as for the pipelines in which they are installed. These instructions only specify those safety instructions which need to be additionally observed concerning sampling valves.

Additional safety instructions are specified in the instructions for the holding fixture.



## 2.2 Safety instructions for the operator

The manufacturer does not assume any responsibility. Therefore, on using the sampling valve, make sure the following instructions are observed:

- ⇒ The valve is to be used only for its intended use as described in section 1.

 <b>Warning</b>	<p><b>Preventing misuse of the sampling valve:</b>  It is especially important to make sure that the selected materials for wetted parts in the sampling valve are suitable for the media used as well as the prevailing pressures and temperatures.  <b>Failure to follow these safety precautions may result in personal injury and can damage equipment installed in the pipeline. The manufacturer does not assume any final responsibility.</b></p>
 <b>Danger</b>	<p><b>Preventing using wrong sample bottles:</b>  The adapter (or various adapters for exchanging) has been matched to the size and shape of the sample bottles to be used as specified by the customer. In the event that other sample bottles are to be used, the customer must consult the manufacturer beforehand to confirm their use.  <b>Failure to follow these instructions may result in personal injury, especially when dangerous media are used.</b></p>
 <b>Danger</b>	<p><b>The valve may only be operated and serviced by personnel appropriately qualified to handle sampling systems.</b>  Skilled staff in the sense of these operating instructions is persons who, as a result of their training, their knowledge and their experience, as well as their knowledge of the relevant standards, are able to judge the tasks assigned to them and are able to recognize possible dangers.  Prior to taking samples of dangerous media, personnel must wear protective clothing (e.g. gloves, goggles), to prevent personal injury that could be caused by any medium escaping during taking a sample.</p>





- ⇒ Make sure the vent bore and drainage line are not blocked.

 <b>Danger</b>	<p><b>Protection against excess pressure in the sample bottle:</b>  The adapter includes a vent bore which prevents pressure from building up in the sample bottle which could destroy the bottle. This vent bore and the connected drainage line may not be blocked and must be cleaned at regular intervals to prevent blockage.  <b>Failure to follow these instructions may result in personal injury, especially when dangerous media are used.</b></p>
 <b>Danger</b>	<p><b>Protection against incorrect use when taking a sample:</b>  To avoid over filling the sample glass, the sampling procedure must be observed at all times.  <b>Failure to follow these instructions, may result in personal injury to the user, especially when using dangerous media.</b></p>
 <b>Danger</b>	<p><b>Protection against over filling the sample glass:</b>  Due to the continuous sampling procedure, a possible rapid over filling of the sample glass may occur, leading to the sampling media being released into the environment.  It is therefore strongly recommended activating the „dead mans control“ by every sampling procedure, in this way the automation is finished automatically on completion of the sampling procedure  <b>Failure to follow these instructions, may result in personal injury to the user, especially when using dangerous media.</b></p>

- ⇒ Make sure that the pipeline have been installed correctly and are checked at regular intervals. The valve body wall thickness must be designed to take into account an additional load  $F_z$  in the usual order ( $F_z = \pi/4 \cdot DN^2 \cdot PS$ ) for a correctly sized pipeline.
- ⇒ The valve needs to be connected correctly to the pipeline.
- ⇒ Make sure the usual flow velocities are not exceeded in continuous service in this pipeline. Exceptional operating conditions such as oscillations, water hammering, cavitation and large proportions of solid matter in the process medium, especially abrasive, must be clarified beforehand with the manufacturer.
- ⇒ Sampling valves that are operated at temperatures greater than +50°C or lower than -20°C must be protected, together with the pipeline connections, against being touched.

 <b>Warning</b>	<p>We recommend to open and close the sampling valve regularly. Depending on the valve model, we recommend opening and closing the valve at least 3x to 4x a year.  Depending on how long the valve remains in one position, breakaway and operating torques may differ considerably than those specified in the data sheet.</p>
---	--

### 2.3 Particular hazards

 <b>Danger</b>	The sampling valve may only be operated under operating conditions after a sample bottle or stopper has been mounted properly underneath the valve. The fixtures approved for this are described in section 6.1.
 <b>Danger</b>	Prior to removing the sampling valve from the pipeline, <b>relieve pressure entirely in the pipeline</b> to ensure the process medium cannot escape uncontrollably from the pipeline.
 <b>Warning</b>	Should it be necessary to remove a sampling valve from the pipeline, process medium may escape from the pipe or out of the sampling valve. In the case of process media that can damage health or are dangerous, drain the pipeline completely before removing the sampling valve from the pipeline. Take special care concerning <b>any remaining media that may still be in the pipeline or have collected in the cavities of the valve</b> .
 <b>Warning</b>	<i>Concerning sampling valves installed for taking samples:</i> Sampling valves without a sample bottle attached must be <b>safeguarded appropriately against unauthorized operation or fitted with a warning notice</b> .

### 2.4 Designation of the sampling valve

The designation of the sampling valve includes the following details:

Details	Designation	Comments
Manufacturer	<b>Pfeiffer</b>	Address, see section 8 <Further information>
Valve type	<b>BR (and number)</b>	e.g. BR 26f = Series 26f, see Pfeiffer catalogue
Body material	<b>e.g. 1.4571</b>	Material number acc. to DIN 10272
Size	<b>DN (and number)</b>	Value in mm, e.g. DN25
Maximum pressure	<b>PN (and number)</b>	Value in bar at room temperature
Perm. temperature	<b>TS (and number)</b>	PS and TS are associated values at maximum permissible operating temperature and maximum permissible operating pressure.
Perm. pressure	<b>PS (and number)</b>	
Serial no. 2009 onwards	<b>e.g.: 271234/001/001</b>	<p>27 1234 /001 /001</p>  <p>Valve no. within item Item in order Order Year of manufacture (e.g. 27=2017, 26=2016, 25=2015)</p>
Serial no. up to 2008	<b>e.g.: 2070153/001/001</b>	<p>207 0153 /001 /001</p>  <p>Valve no. within item Item in order Order Year of manufacture (e.g. 206=2006, 207=2007, 208=2008)</p>
Year of manufacture	<b>e.g.: 2017</b>	The year of manufacture is stamped on the valve upon customer request.
Conformity	<b>CE</b>	Conformity is certified separately by the manufacturer
Identification no.	<b>0035</b>	Notified body as per EU Directive = TÜV Rheinland Service GmbH
Direction of flow	<b>➔</b>	Note: see note in section 4.2 <Installation instructions>

Table 1 – Designation of the sampling valve

Keep the labelling on the valve body and on the nameplate to ensure that the valve can be identified at all times.

### 3. Transport and storage

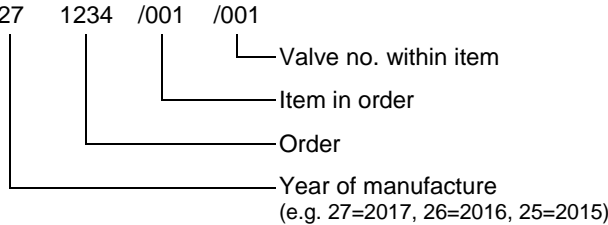
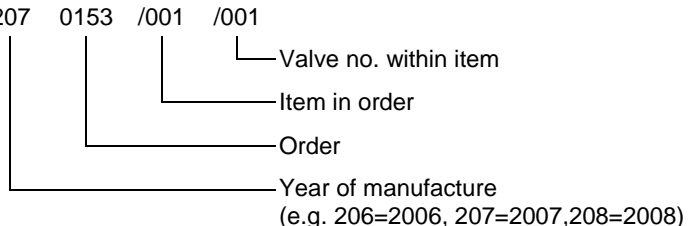

Sampling valves must be carefully handled, transported and stored:

- ⇒ Store the valve and accessories included in the scope of delivery for the sample bottles with its protective packing and/or with its protective caps in place in the end connections. Store and transport the valves that weigh over approx. 10 kg on pallets (or a similar type of support) right up to the point of installation.
- ⇒ Store the valve and accessories included in the scope of delivery in a closed room before it is installed. Protect it against damaging influences such as dirt or moisture.
- ⇒ Make sure, in particular, that the plastic-lined facings of the flanges intended to connect the valve to the pipeline are not damaged through mechanical or other influences. Do not stack sampling valves!
- ⇒ Store the sampling valves in the condition they were delivered in. Do not operate the actuating device.

### 4. Installation in the pipeline

#### 4.1 General

The same instructions apply for installing the sampling valves in the pipeline as for connecting pipes and similar pipeline equipment. The following instructions additionally apply for sampling valves. Also observe section 3 for transporting the sampling valve to the point of installation.

 <b>Warning</b>	Sampling valves may only be installed in pipelines in such a way that the sample bottle is vertically suspended. Make sure sufficient space is left underneath the valve for connecting and handling the sample bottles. Refer to Data Sheet <TB27f> for these dimensions.
 <b>Note</b>	The mating flanges must have smooth facings Contact the manufacturer if you intend to use other flange forms.

#### 4.2 Installation instructions

- ⇒ Transport the valve in its original packaging right up to the point of installation. Remove packaging first at the point of installation to protect it from dirt.
- ⇒ Check valve for signs of damage that may have occurred during transportation. Do not install a damaged sampling valve.
- ⇒ Prior to installation, carry out a function check. The sampling valve must open and close properly. Any function errors that are recognized must be remedied before commissioning. See also section 7 <Troubleshooting>.
- ⇒ Make sure that only sampling valves are installed when their pressure rating, end connections and face to face dimensions match the conditions of application. See the designation of the sampling valve.

 <b>Danger</b>	<p>Do not install a sampling valve if its permissible pressure/temperature ranges do not apply to the operating conditions. The limits of application are marked on the valve, see section 2.4 &lt;Designation&gt;. The permissible range is determined in section 1 &lt;Intended use&gt;.</p> <p><b>Failure to follow these safety precautions may result in personal injury and can damage equipment installed in the pipeline.</b></p>
--	---

- ⇒ Make sure the end connections of the pipeline are aligned with the sampling valve's end connections and their ends have parallel planes.
- ⇒ Prior to installation, carefully clean the valve and the connecting section of the pipeline from dirt, especially hard foreign material.
- ⇒ Make sure, in particular, that flange facings (and any flange gaskets) are free from any dirt prior to installation.
- ⇒ On inserting the valve (and any flange gaskets) into a ready mounted pipeline, keep a certain clearance between the pipeline ends to ensure that all facings (and gaskets) remain undamaged.

⇒ Make sure the arrow on the valve body corresponds with the direction of flow in the pipeline.

 <b>Note</b>	<p>In special cases, it may be necessary for the valve to be tightly shut against the direction of flow. The installation in such special cases <b>must be determined by the operator of the pipeline</b> (e.g. to protect a pump).</p>
--	---

### 4.3 Attachment of an additionally supplied holding fixture for sampling bottles

⇒ The design and size of the holding fixture has been adapted to the sampling bottles used as specified by the customer. If another holding fixture is intended to be used, Pfeiffer must first check it and approve its use.

 <b>Danger</b>	<p>If a holding fixture is to be retrofitted, it must be adapted to the sampling valve and sampling bottle. <b>Failure to follow these safety precautions may result in personal injury and can damage the pipeline.</b></p>
--	--

## 5. Pressure check in pipeline section

The pressure check of valves has already been carried out by the manufacturer. To check the pressure of a section of pipeline with installed valves, the following points must be observed:

- ⇒ Carefully flush newly installed pipes to remove any foreign material.
- ⇒ **Valve OPEN:** The test pressure should not exceed the value **1.5 x PN** (see nameplate).
- ⇒ **Valve CLOSED:** The test pressure should not exceed the value **1.1 x PN** (see nameplate).

If a valve leaks, see section 7 <Troubleshooting>.

## 6. Standard operation and maintenance

### 6.1 Sample bottle fixture

- ⇒ Check the vent bore regularly to ensure that the media is able to flow out through the drainage line (in case the bottle is overfilled unintentionally) and to make sure it is not blocked.
- ⇒ On cleaning, observe the instructions described in section 2 <Safety instructions> and section 7 <Troubleshooting>.

### 6.2 Sampling valve

- ⇒ The shaft is sealed with a V-ring packing preloaded with a set of spring washers and does not require any maintenance.
- ⇒ Regular maintenance work on the sampling valves is not necessary. But, on checking the pipeline section, there should be no leakage at the flanged and bolted connections of the valve body or at the shaft packing.
- ⇒ If a valve leaks, proceed as described in section 7 <Troubleshooting>.

### 6.3 Manual operation

- ⇒ Normal manual force is sufficient to operate the manual operation. Turn the lever clockwise to close the valve. It is not permissible to use extensions to increase the operating torque.

 <b>Danger</b>	<p><i>Sampling valve with star lever, or dead mans control:</i>  Do not open or close the valve with sudden movements, but quick enough to prevent pressure surges and/or temperature shocks occurring in the pipeline. <b>Failure to follow these safety precautions may result in serious personal injury and can damage equipment installed in the pipeline.</b></p>
--	---

## 7. Troubleshooting

Observe the safety instructions listed in section 2 on troubleshooting.

 <b>Warning</b>	<p>To remove a valve from a pipeline containing dangerous media and to take it out of the plant: Decontaminate the valves properly first.</p>
---	---

Type of fault	Action to be taken	Comment
Leak at the connection to the pipeline	Tighten flange bolts. <i>If the medium leaks out at the flanges even after tightening the flange bolts:</i> Remove the valve (observing the instructions in section 2.3 <Particular hazards>) and replace the gaskets.	<p><b>Note 1:</b> <i>When ordering spare parts, include all the specifications listed in the valve designation. Only use original parts from Pfeiffer.</i></p> <p><b>Note 2:</b> <i>If, after removing the valve from the pipeline, it is found that the body and/or internal parts are not sufficiently resistant to the process medium, select parts made of a suitable material.</i></p>
Leak at the Seat	Tighten threaded bushing. <i>If the valve still leaks:</i> Remove the valve (observing the instructions in section 2.3 <Particular hazards>) and replace the gaskets. Contact Pfeiffer for spare parts and necessary instructions.	
Leak at the shaft packing	Remove the valve (observing the instructions in section 2.3 <Particular hazards>), dismantle the valve and replace the shaft packing. Contact Pfeiffer for spare parts and necessary instructions.	
No tight shut-off when the valve is closed	Remove the valve (observing the instructions in section 2. 3 <Particular hazards >) and check it. <i>If the valve is damaged:</i> If it must be repaired, remove the valve, observing section 2.3 <Particular hazards>. Contact Pfeiffer for spare parts and necessary instructions.	
Malfunction	Remove the valve (observing the instructions in section 2.3 <Particular hazards>) and check it. <i>If the valve is damaged:</i> If it must be repaired, remove the valve, observing section 2.3 <Particular hazards>. Contact Pfeiffer for spare parts and necessary instructions.	

## 8. Further information

Contact the address below for the listed <Data sheets> and <Repair instructions> as well as further information.

### Pfeiffer Chemie-Armaturenbau GmbH

Hooghe Weg 41 • 47906 Kempen

Phone: +49 21 52 20 05 - 0 • Fax +49 21 52 15 80

E-Mail: [vertrieb@pfeiffer-armaturen.com](mailto:vertrieb@pfeiffer-armaturen.com) • Internet: [www.pfeiffer-armaturen.com](http://www.pfeiffer-armaturen.com)